



Sight Glass Level Gauges Type - LGG

Description

Level Gauges for direct reading of liquid levels in vessels and tanks.

Applications

- Refineries
- Off-shore
- Oil and gas
- Power stations
- Chemical plants
- Thermofluid oil installations
- Refrigerating plants
- Cryogenic services

Rating

- Pressure rating PN 6 – 250
- Operating temperatures from – 200 up to + 400 °C

Product groups

- Reflex type
- Transparent type with glass or mica
- Refraction type
- Tubular type

Chambers

- fixed, flanged, pivoted, screwed or weldable
- interrupted or continuous visible length

Materials

- Forged steel, stainless steel, suitable for pressure equipment according to EN or ASME
- Particularly corrosion resistant materials as Duplex, Monel, Inconel, Hastelloy, Titanium, etc.

Shut-off valves

- handwheel or quick closing lever
- with ball check
- flanged or union connection

Accessories

- Drain and vent
- Illumination
- Heating
- Scale
- Frost protection
- Ultraviolet protection
- Corrosion protection
- Lining/coating PTFE/Halar, rubber

Certificates

- Test certificates according to DIN EN 10204
- Sour gas regulation NACE
- Tests to customers requirements

Necessary data

Glass type, Design pressure (p), Design temperature (T), center to center distance (ME), visible length (SL), materials, process connection, ex classification, quantity

Special constructions available upon request.
For further details please use our datasheets.

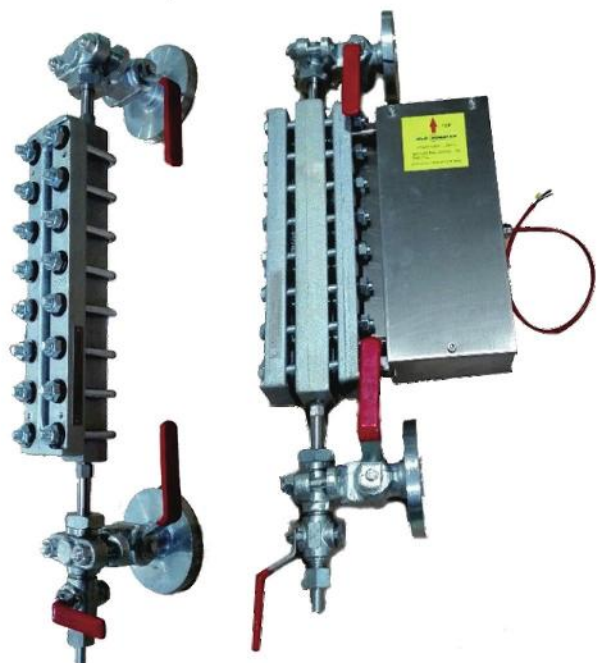

Functional Description Sight Glass Level Gauges

Reflex glass type acc. to DIN 7081

Incident light is reflected at the reflex grooves of the sight glass plate covered by gas and is broken into the liquid in the part covered by medium. The liquid level is visible as a dark bar, the gaseous space as a silvery bar.

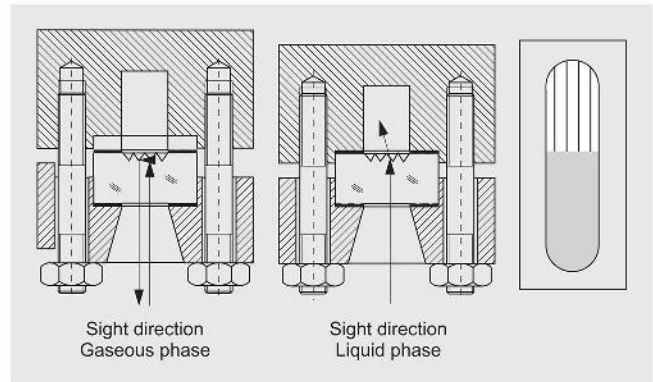

Transparent glass type acc. to DIN 7081

Incident light is reflected at the reflex grooves of the sight glass plate covered by gas and is broken into the liquid in the part covered by medium. The liquid level is visible as a dark bar, the gaseous space as a silvery bar.

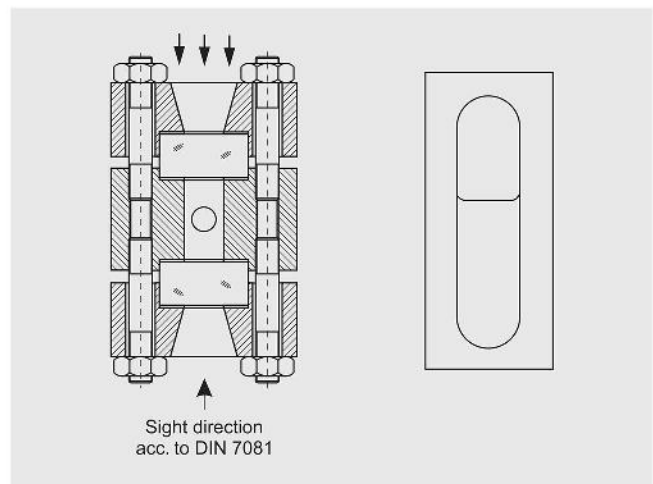

Refraction type with mica sheets

The incident light of a lamp is guided through the two mica sheet packages in an angle and passes the medium between them. In gaseous phase the light is guided straight forward and passes both mica packets, in liquid the light is refracted away. The liquid level is visible as a black bar and the gas as a bright bar.

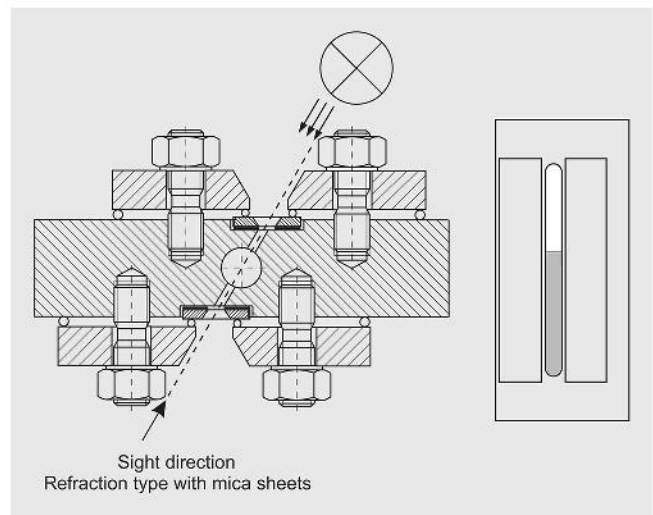

Design Sight Glass Level Gauges

The main part of the sight glass level gauge is the chamber. A duct for the medium (or heating agent) is machined into the gauge body as well as the support surfaces for the gaskets and glasses or micas. Glass plates and/or micas are mounted with gasket and cushion and are fixed with the cover plate or pressure frames and bolts. The glass plates used for sight glass level gauges correspond to DIN 7081 and are suitable for temperatures up to 243 °C (280 °C when protected with mica) for steam, up to 300 °C for other liquids, and in special

cases up to 400 °C. Borosilicate glass is standard quality. For conditions above the natural mineral mica is used. The process connection normally is equipped with gauge valves. Drain valves are used for draining the gauge and are generally mounted on the lower end of the gauge body. In Special cases a vent valve can be installed on the upper end.

Gauge body

Contains the liquid duct, the level corresponds with the level in the vessel.

Cover

Clamping for Glass plate.

Gasket

Recessed sealing between liquid duct and ambient

Glass

Glass plates according to DIN 7081, made of Borosilicate-Glass, quartz, Aluminum silicate

Cushion

Mechanical protection between cover and glass

Bolt / Nut

Take up the forces of the pressure inside.

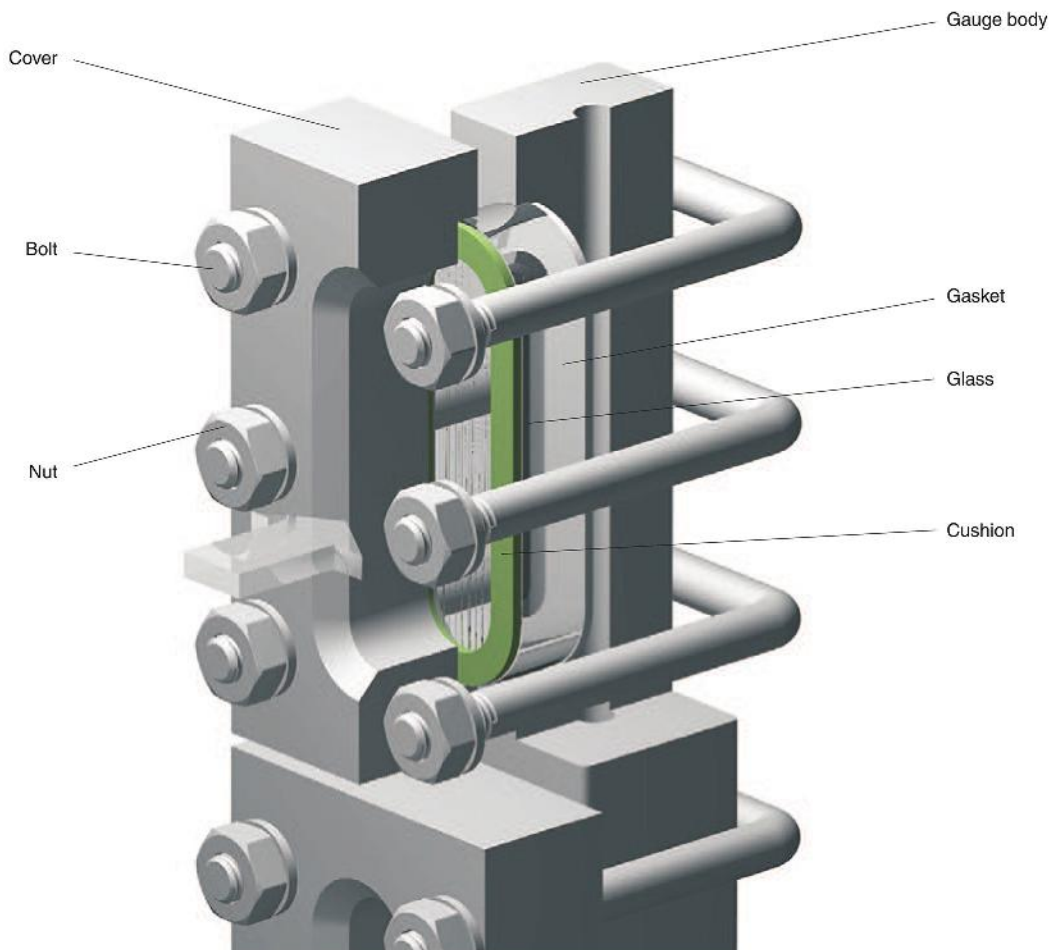

Sight Glass Level Gauge CL 300

Type LGG - TP

Applications

Direct reading liquid level indicator for general applications up to CL 300 (depends on glass type).
Increased safety with ball check valves.

Special Features

- Light execution
- Reflex, Transparent
- Connection top-bottom pivoted
- Connection gauge valve to gauge chamber: union
- Offset, handwheel

General Data

Visible length SL	< ME – 180 mm
Connection gauge valve-body	union
Gauge valve types	see datasheet 760.53
Actuation	handwheel
Material glass plates acc. to DIN7081	Borosilicate
Material media wetted parts	CS, SS

Depending on delivery situation material can vary.
Types with special materials e.g. Hastelloy, Monel etc. are available.

Design Data

Derating depends on temperature and window size.

Further Data

Process connection	see Connections
Vent	see Connections
Drain	see Connections

Accessories

Glass protection etc.	see Accessories
Frosts protection	see Accessories
Illumination	see Accessories
Scale	see Accessories
Heating	see Accessories

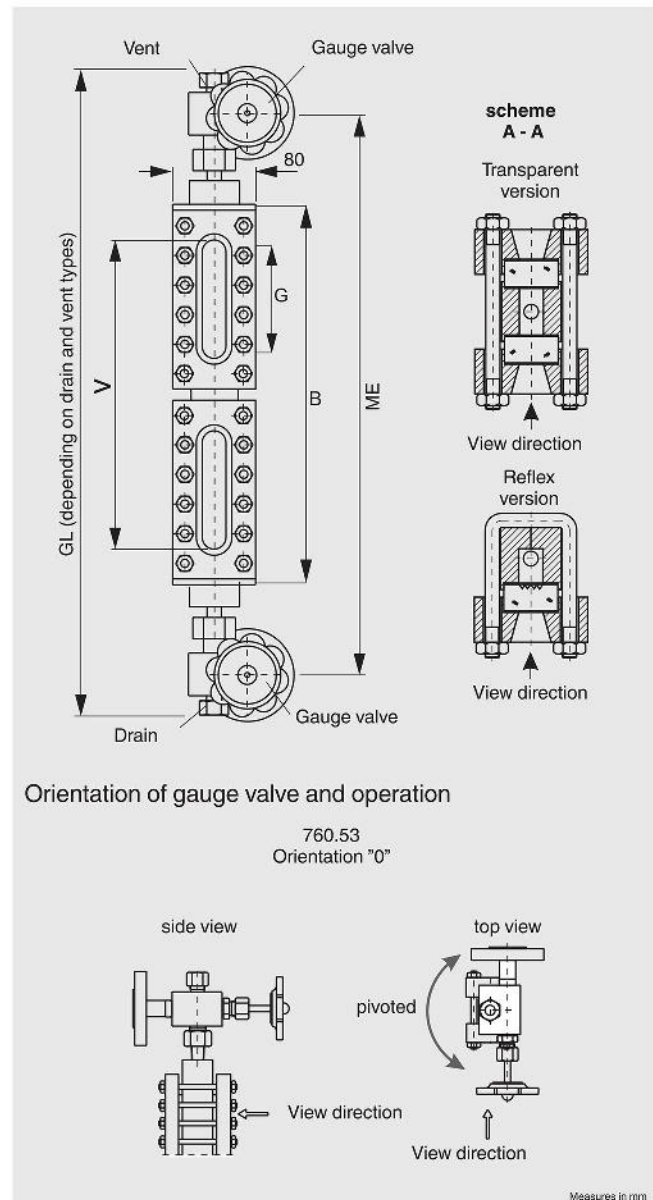

CS (= carbonsteel) and SS (= stainless steel type 316SS) are materials suitable for Pressure Vessels according to EN or ASME.

Size	1	2	3	4	5	6	7	8	9	2x4	2x5	2x6	2x7	2x8	2x9	3x6	3x7	3x8	3x9	4x7	4x8	4x9	5x7	5x8	5x9	6x8	6x9	7x9
Length of glass G	115	140	165	190	220	250	280	320	340	190	220	250	280	320	340	250	280	320	340	280	320	340	280	320	340	320	340	340
Length of body B	165	190	215	240	270	300	330	370	390	450	510	570	630	710	750	840	930	1050	1110	1230	1390	1470	1530	1730	1830	2070	2190	2550
Visible length V	95	120	145	170	200	230	260	300	320	380	440	500	560	640	680	770	860	980	1040	1160	1320	1400	1460	1660	1760	2000	2120	2480
CC (ME)	278	303	328	353	383	413	443	483	503	563	623	683	743	823	863	953	1043	1163	1223	1343	1503	1583	1643	1843	1943	2183	2303	2663

Reflection Water Level Gauge CL 300

Type LGG - RP

Applications

The liquid water level gauge type LGG-RP is a reflection gauge for direct reading water level in steam boilers. They are equipped with sight glasses with grooves for a clear contrast in the display.

Special Features

- Reflection
- Connection side-side fixed
- Gauge heads integrated
- Glass holder: side plates, hinged
- Handwheel

General Data

Sight length SL*)	<ME
Glass size**)	2 – 11 (34 x 17 mm)
Actuation	handwheel
Connection gauge head-body	valves integrated
Valve passage	8 mm
Process connection	flange DIN, EN or ANSI
Materials	
- Sight glasses DIN 7081	Borosilikate
- Glass holder	CS
- Connection flanges	CS
- Shut off parts	SS
- Gaskets	Graphite

Design Data

Design temperature / Design pressure	-10...100°C / 40 bar up to 200°C / 32 bar up to 243°C / 30 bar
--------------------------------------	--

Accessories

Pointer	NW-mark acc. to TRD
For shut off valves	automatically closing ball (safety device) (at least 1 bar pressure tanks required for the function)
Glass protection	Mica exterior protection

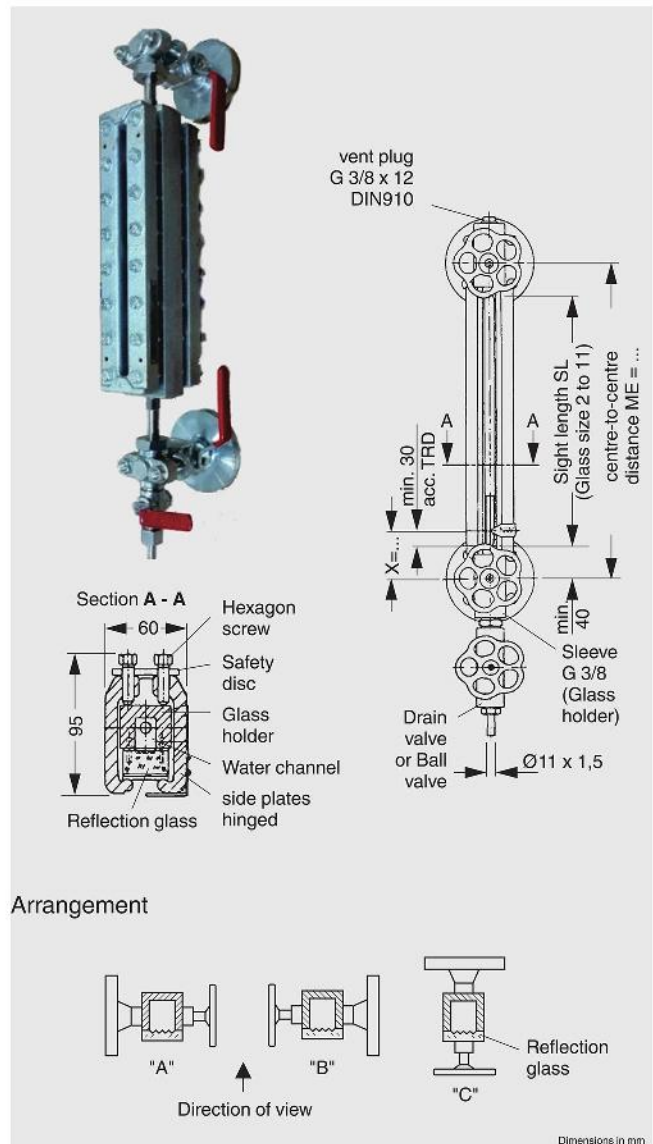

*) Sight length „SL“ = min. center-center-distance ME – 80 mm
 Interruption between 2 sight glasses: min. 50 mm
 **) Other glass sizes available on request.
 CS (= carbonsteel) and SS (= stainless steel type 316SS) are materials suitable for Pressure Vessels according to EN or ASME.

Glass size / range of centre-to-centre distance

Size	1	2	3	4	5	6	7	8	9	24	25	26	27	28	29	36	37	38	39	47	48	49	57	58	59	68	69	79
Length of glass G	115	140	165	190	220	250	280	320	340	190	220	250	280	320	340	250	280	320	340	280	320	340	280	320	340	320	340	340
Length of body B	128	153	178	203	233	263	293	333	353	413	473	533	593	673	713	803	893	1013	1073	1193	1353	1433	1493	1693	1793	2033	2153	2513
Visible length V	95	120	145	170	200	230	260	300	320	380	440	500	560	640	680	770	860	980	1040	1160	1320	1400	1460	1660	1760	2000	2120	2480
CC.min With GP11	241	266	291	316	346	376	406	446	466	526	586	646	706	786	826	916	1006	1126	1186	1306	1466	1546	1606	1806	1906	2146	2266	2626
CC.min With GP12	209	234	259	284	314	344	374	414	434	494	554	614	674	754	794	884	974	1094	1154	1274	1434	1514	1574	1774	1874	2114	2234	2594
CC.min With GP11	229	254	279	304	334	364	394	434	454	514	574	634	694	774	814	904	994	1114	1174	1294	1454	1534	1594	1794	1894	2134	2254	2614
CC.min With GP12	182	207	232	257	287	317	347	387	407	467	527	587	647	727	767	857	947	1067	1127	1247	1407	1487	1547	1747	1847	2087	2207	2567
Weight kg	11,7	12,1	12,9	13,3	14,1	15	15,5	16,5	17,2	18,2	19,8	21,7	22,6	24,6	26	28,4	29,8	32,8	34,9	36,9	40,9	43,7	44,3	49,1	52,6	57,2	61,4	70,3

Glass size / range of centre-to-centre distance

Glass size*	2	3	4	5	6	7	8	9
Glass length / mm	140	165	190	220	250	280	320	340
SL per segment	120	145	170	200	230	260	300	320
min. center-to-center-distance / mm								
1 x glass size	200	225	250	280	310	340	380	400
2 x glass size				525	590	650	730	770
3 x glass size				770	870	960	1080	1140
4 x glass size				1015	1135	1255	1415	1495
5 x glass size				1280	1410	1560	1760	1860

* Reflection glasses DIN 7081, width 34 mm, thickness 17 mm

Sight length SL = min. center-to-center-distance ME – 80 mm
Interruption between 2 sight glasses min. 45 mm

Design Data

Design pressure PN 40 (with shut-off valve)	
Design temperature*	Design pressure
– 10 ... 120 °C	40 bar
– 10 ... 200 °C	35 bar
– 10 ... 243 °C	32 bar

max. temperature for reflection glass acc. to DIN 7081 = 243 °C

*Design – 60°C available on request

Anordnung C

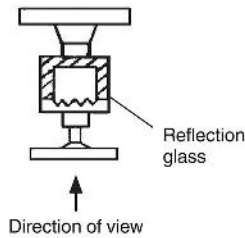

Valve Drawing Type BM-11

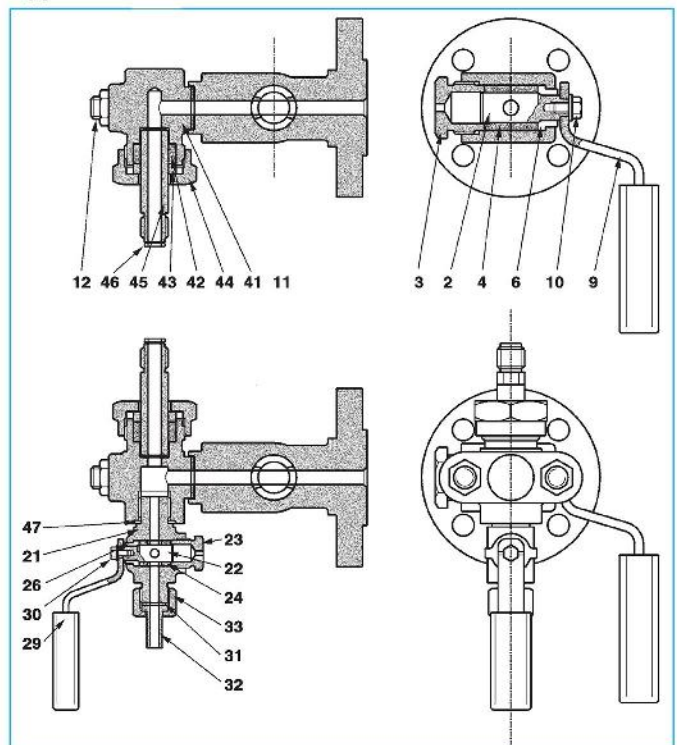

Illumination Transparent Sight Glass Level Gauges

Type LGG-TP-IL



Applications

The illuminations are designed for illuminating sight windows according to DIN 7081 and mica sight windows. By variation segment length and number of segments as well as the optical power illumination can be adapted to most applications.

Can be operated in hazardous area.

Special Features

- Even bright illumination
- Bulb, highlight-performance and long lifetime

General Data

Material housing lamp	Alu
Material reflector	Glass, Acryl-Glass, mirror sheet
Dimensions	
- A	ca. 160 mm
- B	up to glass size 12 ca. 200 mm from glass size 12 ca. 300 mm
Weight	1,8kg

Design Data

Ex-classification	II 2 GD Ex d(Ex de) IIC T2...T6
Surface temperature	depends on temperature class and lamp power
Ambient temperature	- 50...+ 55°C

Electrical Data

Power supply	120 / 230 VAC
Lamp power	max. 100 W
Illustration	Halogen bulb
Lamp holder	E 27
Ingress protection	IP 66

Certificates

EC-Type Examination Certificate CESI 01 ATEX 028

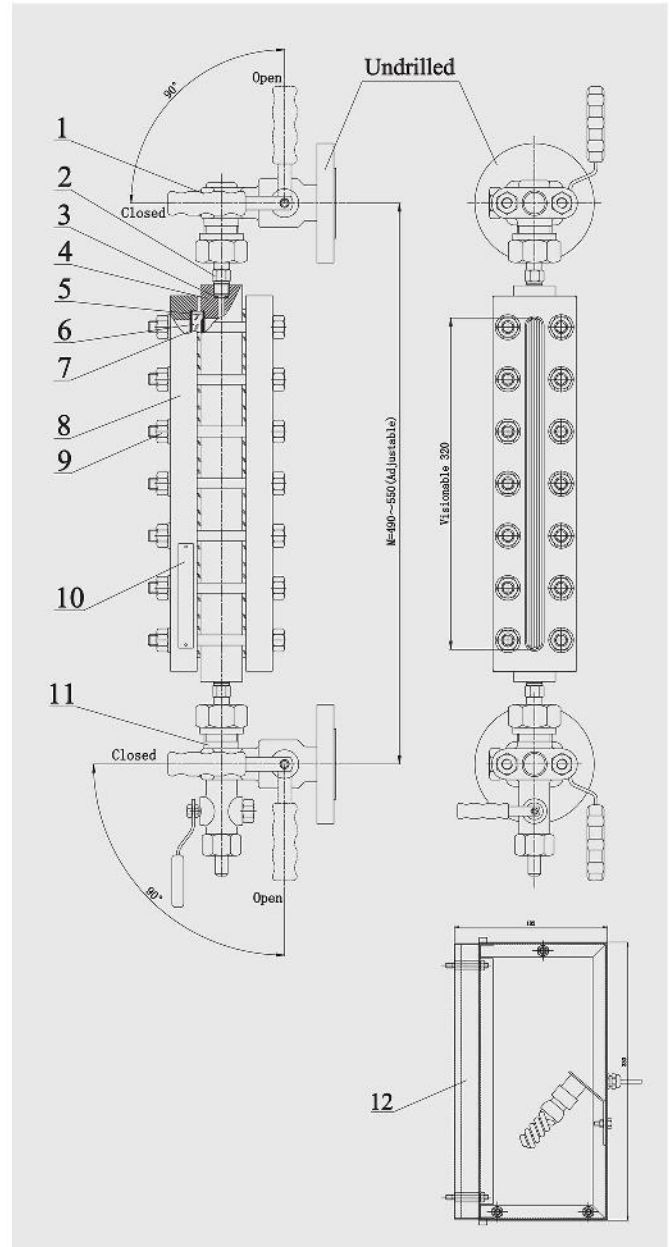

Temperature (°C)	Pressure (MPa)	Process Standard
≤ 250	≤ 4.0	ASME B16.5

No.	Quantity	Name	Code	Material	Remark
12	1	Illuminator	AC 230V 15W	/	Ambient T:50°C
11	1	Needle valve with drain valve	3/4"/300LB/RF	ASTM A105	
10	1	Nameplate	English	SS 304	
9	16	Fastener	M10×130	35CrMo 8.8	
8	2	Size 9 cover	80×25×360	ASTM A105	
7	2	Size 9 gasket	340×34×1.0	Reinforced graphite	
6	2	Size 9 glass	340×34×17	Tempered borosilicate glass	
5	2	Size 9 gasket	340×34×1.0	Reinforced graphite	
4	1	Body	40×40×380	ASTM A105	
3	2	Sealed	Ø14.8×Ø8×2	Red copper	
2	2	Branch pipe	Ø16	ASTM A105	
1	1	Needle valve	3/4"/300LB/RF	ASTM A105	

Specification is subject to change without prior notice

Sight Glass Level Gauges Accessories

Frost protection

Material: PMMA (Plexiglas)

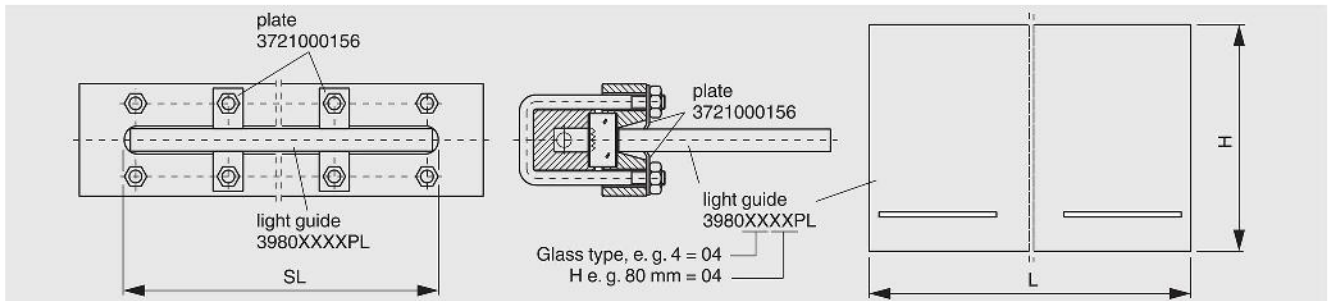

Glass type	0	1	2	3	4	5	6	7	8	9	10	11	12	13	14	15	16	17	18	19	20
L	72	92	117	142	167	197	227	257	297	317	347	377	407	437	477	507	537	577	607	637	677

H in mm covers temperature in °C below zero, standard heights: 80, 120, 180 und 200 mm recommended types

Flat glasses

acc. to DIN 7081

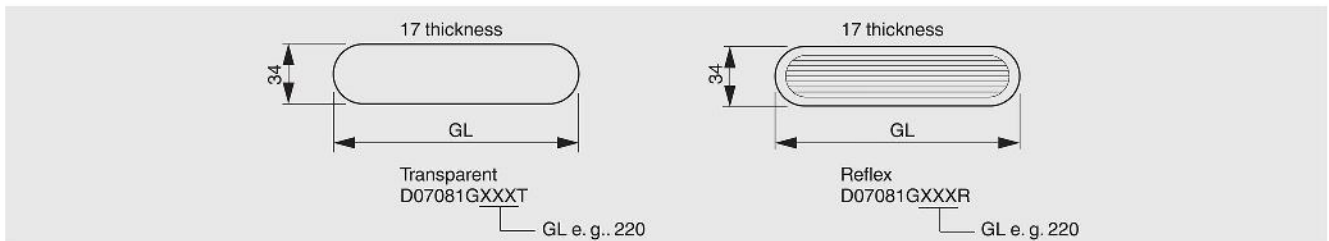

Glass type	0	1	2	3	4	5	6	7	8	9	10	11	12	13	14	15	16	17	18	19	20
GL	95	115	140	165	190	220	250	280	320	340	370	400	430	460	500	530	560	600	630	660	700

recommended types

Gaskets

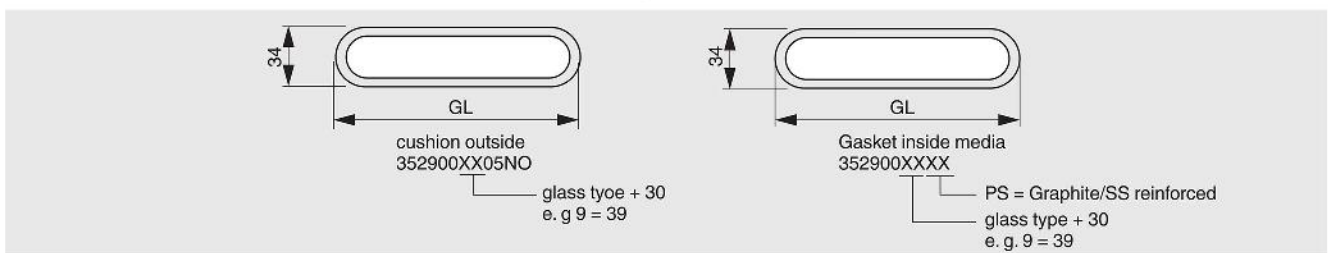

Glass type	0	1	2	3	4	5	6	7	8	9	10	11	12	13	14	15	16	17	18	19	20
GL	95	115	140	165	190	220	250	280	320	340	370	400	430	460	500	530	560	600	630	660	700

recommended types

Mica and gasket



mica round
34 mm wide, 0,2 – 0,3 thick
corrosion protection



mica round
24 mm wide
0,13 thick



gasket graphite with
SS-inlay for mica round,
24 mm wide

mica size	L	mica round 34 mm wide 0,2 – 0,3 mm	mica round 24 mm wide 0,13 mm	gasket graphite-SS 24 mm wide	mica package round, 24 mm wide		
					0,9 – 1,0 mm thick	1,2 mm thick	1,7 mm thick
0	95	39890800GL	39897700GL	418D10200VG	39893700GL	39894700GL	39896700GL
1	115	39890801GL	39897701GL	418D10201VG	39893701GL	39894701GL	39896701GL
2	140	39890802GL	39897702GL	418D10202VG	39893702GL	39894702GL	39896702GL
3	165	39890803GL	39897703GL	418D10203VG	39893703GL	39894703GL	39896703GL
4	190	39890804GL	39897704GL	418D10204VG	39893704GL	39894704GL	39896704GL
5	220	39890805GL	39897705GL	418D10205VG	39893705GL	39894705GL	39896705GL
6	250	39890806GL	39897706GL	418D10206VG	39893706GL	39894706GL	39896706GL
7	280	39890807GL	39897707GL	418D10207VG	39893707GL	39894707GL	39896707GL
8	320	39890808GL	39897708GL	418D10208VG	39893708GL	39894708GL	39896708GL
9	340	39890809GL	39897709GL	418D10209VG	39893709GL	39894709GL	39896709GL
10	370	39890810GL	39897710GL	418D10210VG	39893710GL	39894710GL	39896710GL
11	400	39890811GL	39897711GL	418D10211VG	39893711GL	39894711GL	39896711GL
12	430	39890812GL	39897712GL	418D10212VG	39893712GL	39894712GL	39896712GL
13	460	39890813GL	39897713GL	418D10213VG	39893713GL	39894713GL	39896713GL
14	500	39890814GL	39897714GL	418D10214VG	39893714GL	39894714GL	39896714GL
15	530	39890815GL	39897715GL	418D10215VG	39893715GL	39894715GL	39896715GL

Mica packages P_{Design}

For each mica window a mica package up to 1,7 mm thickness and a gasket for each package is needed.

package thickness	P _{Design} [bar]		
	80	120	150
0,9 – 1,0	X		
1,2		X	
1,7			X

Dimensions in mm

Corrosion protection

Corrosion protection for sight glasses from water side acc.to DIN 7081 above 243 °C 1 mica sheet is needed.

Pointer low water

Form, size and inscription vary depending up on execution of the boiler level gauge.

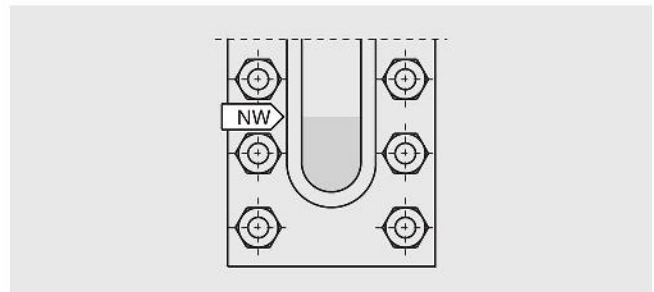

Specification is subject to change without prior notice

Corrosion protection with mica

for transparent glasses acc. to DIN 7081

As corrosion protection you shall use 1 mica sheet with 0,2 to 0,3 mm thickness fitted to the inner side of a transparent glass acc. to DIN 7081 (marking 'waterside' inward).

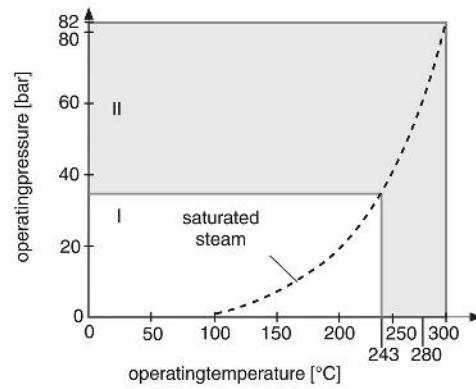

I	saturated steam, glass without protection
II	saturated steam, glass with mica protection

Corrosion protection and anti-adhesive

FEP-foil thickness 0,1 mm for transparent glasses acc. to DIN 7081 up to + 200 °C, as corrosion protection or as anti-blocking means for media which are adherent to glass

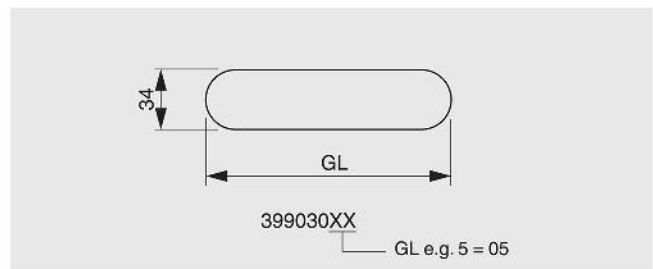

Glass type	0	1	2	3	4	5	6	7	8	9	10	11	12	13	14	15	16	17	18	19	20
L	72	92	117	142	167	197	227	257	297	317	347	377	407	437	477	507	537	577	607	637	677

Scale

- Foil on Aluminum graduated in cm (up to 100 °C)
- Foil on SS graduated in cm (up to 100 °C)
- SS engraving graduated in cm
- Pointer for water low indication, material Aluminum

Heating

- Steam heating

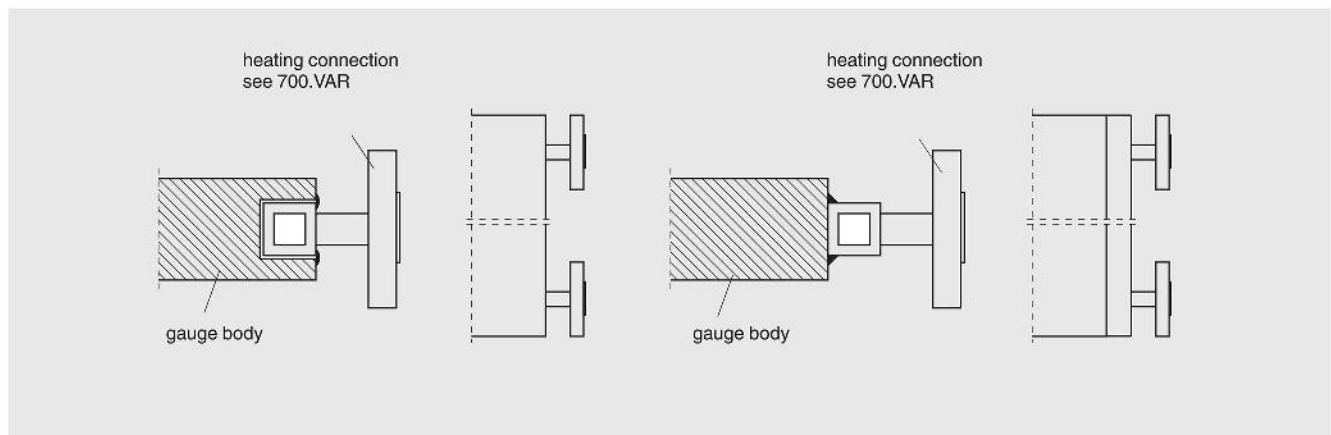

Orientation of the heating connection by customers specification. Electrical heating also possible.